



MOONRAKER

Type HF FB3-30

HF broadband wire marine antenna (No ATU required)

A compact efficient HF broadband shipboard antenna designed to provide effective short to medium range communications without the need for an antenna coupler, particularly for fishing boats 12 metres (40ft) or longer.

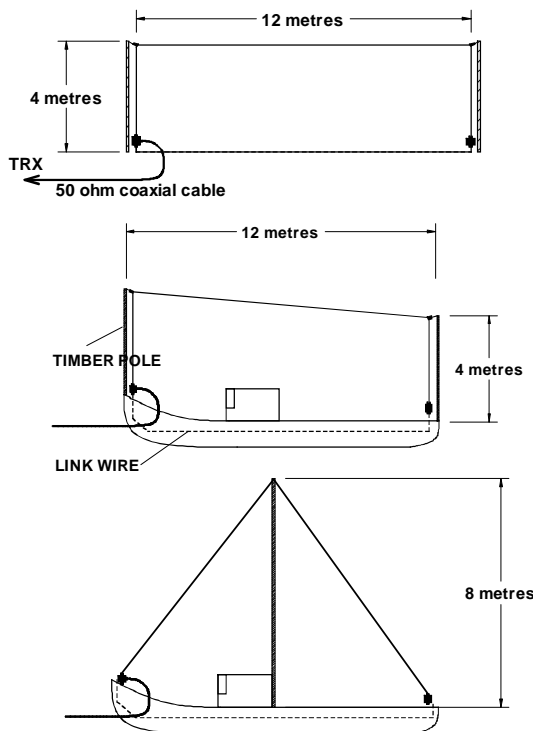

The HF FB3-30 antenna system is compact in size, easily erected in either a *horizontal* configuration from supports at the bow and stern of the vessel or in an *inverted V* configuration using the mast as a central support. In the horizontal configuration the mast supports may be level or sloping to maximise high level radiation for short range communications. Wooden masts are best and support insulators are provided. In the inverted V configuration a masthead insulator is provided to suspend the middle of the antenna from the mast.

The radiating element is stainless steel wire rope to provide protection from environmental damage and long life. Fittings are also of stainless steel with high quality insulators. The antenna is supplied complete with all fittings, including a socket for connection of coaxial cable to transceiver. Coaxial cable is not supplied.

A higher power 1kW PEP version is also available.

The system provides efficient communications over the HF range from 3 to 30 MHz without an ATU (coupler).

SPECIFICATIONS

Antenna Length	30m (98ft)
Frequency Range	3-30 MHz
Impedance	50 Ω (nominal)
VSWR	<2.5:1
Radiation Pattern	High angle omnidirectional (azimuth)
Power Capability	standard version 100w CW, 250w PEP; high power version 300w CW, 1kW PEP
Connector	UHF SO239 socket
Connection	via coaxial cable (option)
Minimum Vessel Length	12 metres (40ft)
Recommended Height	Inverted V: 1 mast, 6m (20ft) minimum at centre Horizontal: 2 masts, 4m (13ft) minimum at centre
Gain (maximum)	better than 5dB
Wind Rating	210 km/h (130 mph)
Weights	standard version - Unpacked: 2.2 kg (4.4 lbs); packed: 2.5kg (5.5 lbs) high power version – unpacked: 3.6kg (7.92 lbs); packed 4kg (8.8kg)
Packed Size	590x295x85mm (23x11.6x3.3 in)

Specifications subject to change 1/02

Moonraker Australia Pty. Ltd. A.B.N. 57 009 531 211

Tasmania Technopark, Dowsing Point 7010, Tasmania Australia

Website: www.moonraker.com.au Telephone 61 (0)3 6273 1533 Fax: 61 (0)3 6273 1749 Email: radiocom@moonraker.com.au